



Case Study

High-Speed Ethernet & TDM Business Services over SDH
Bezeq, Israel



Application

High-Speed Ethernet and TDM
Business Services over SDH

Challenge

Diversify portfolio and introduce
NGN services by leveraging existing
assets

Solution

RAD's Ethernet network termination
units, gateways and terminal
multiplexers/ADMs

Benefits

- Reduces maintenance costs
- Saves space
- Reduces total cost of ownership (TCO)

RAD Solution Smooths Incumbent Carrier's Migration to Next Generation Networking

Established in 1984, Bezeq is Israel's incumbent carrier and largest telecommunications service provider. With a market share of approximately 85% of voice traffic and 80% of data traffic, Bezeq and its subsidiaries offer the full range of telecommunication services including domestic, international and cellular phone services, broadband Internet and other data communications services, multi-channel television, leased lines, and corporate networks.

Bezeq aims to lead the market in both infrastructure and services, providing managed solutions to large enterprises, delivering broadband and interactive services to SMBs and the customer residence, as well as Next Generation mobile and wholesale network services.

Enhanced Service Offerings to Businesses

Intensified competition, however, is driving Bezeq not only to enhance its service offerings to businesses but also reduce operating costs. It decided, therefore, to leverage its large SDH transport network to offer high-speed Ethernet and traditional TDM services, especially for the banking and financial services industries. For that reason, it is migrating its backbone network to packet and requires compact devices that enable a smooth hand-off of services from SDH transport to its Metro Ethernet network.

“This equipment lets us diversify the services we give our customers using the same CPE equipment.”

Moshe Antebi, Bezeq Transmission Technician



data communications

After rigorous testing, Bezeq selected RAD's Ethernet network termination units, gateways and terminal multiplexers/ADMs as the standard access CPE for these enhanced services. "This equipment lets us diversify the services we give our customers using the same CPE equipment," explains Moshe Antebi, Bezeq Transmission Technician. "It also lets us offer lines with capacity of 2, 4, 8, 10, 20, 60 Mbps and aggregate several branch offices over the same trunk and transport to the main headquarters and DRP," he continues. "Deploying the equipment in our operating centers gives us greater leeway for maintenance and also takes up less space at the customer premises."

"The benefit of using an integrated RAD solution installed at the customer site is that it really gives us the flexibility to manage all of the products remotely, and this is really an advantage from our point of view," said Kobi Paz, Bezeq's Vice President of Business Services. "We have less demand to send employee technicians to the customer site in order to do maintenance, installation, and install additional services at the customer premises, and therefore, the cost to maintain and to install new services has been really reduced," he adds. "This is one of the reasons we chose RAD equipment, because it really is the best in class in this respect."

“The benefit of using an integrated RAD solution is that it really gives us the flexibility to manage all of the products remotely”

Kobi Paz, Bezeq Vice President of Business Services

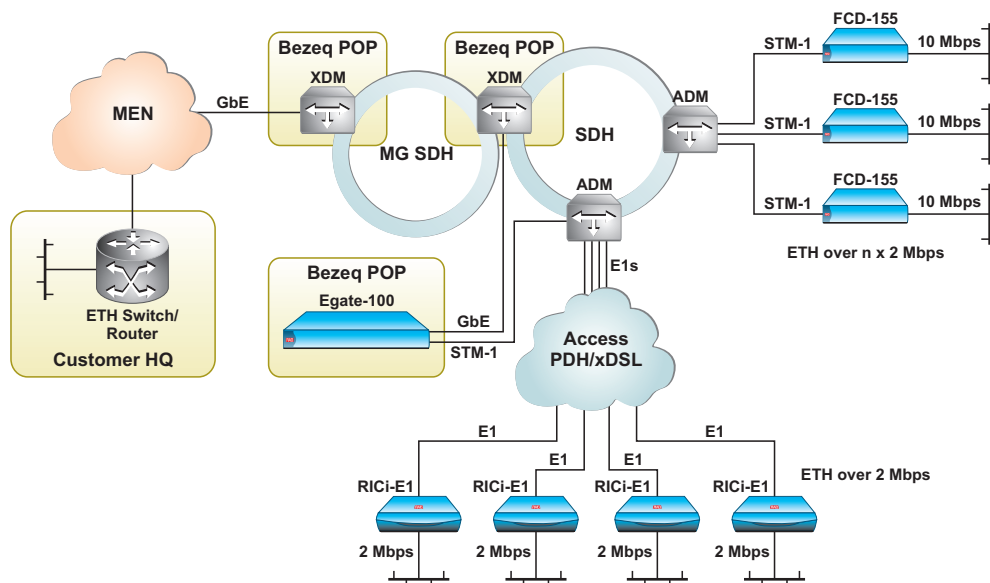

Corporate Headquarters

RAD Data Communications Ltd.
24 Raoul Wallenberg Street
Tel Aviv 69719, Israel
Tel: 972-3-6458181
Fax: 972-3-6498250
email: market@rad.com
www.rad.com

US Headquarters

RAD Data Communications Inc.
900 Corporate Drive
Mahwah, NJ 07430, USA
Tel: (201) 529-1100
Toll free: (800) 444-7234
Fax: (201) 529-5777
email: market@radusa.com

www.rad.com



data communications