



# Wholesale Networking

Application Brochure



Wholesale Services

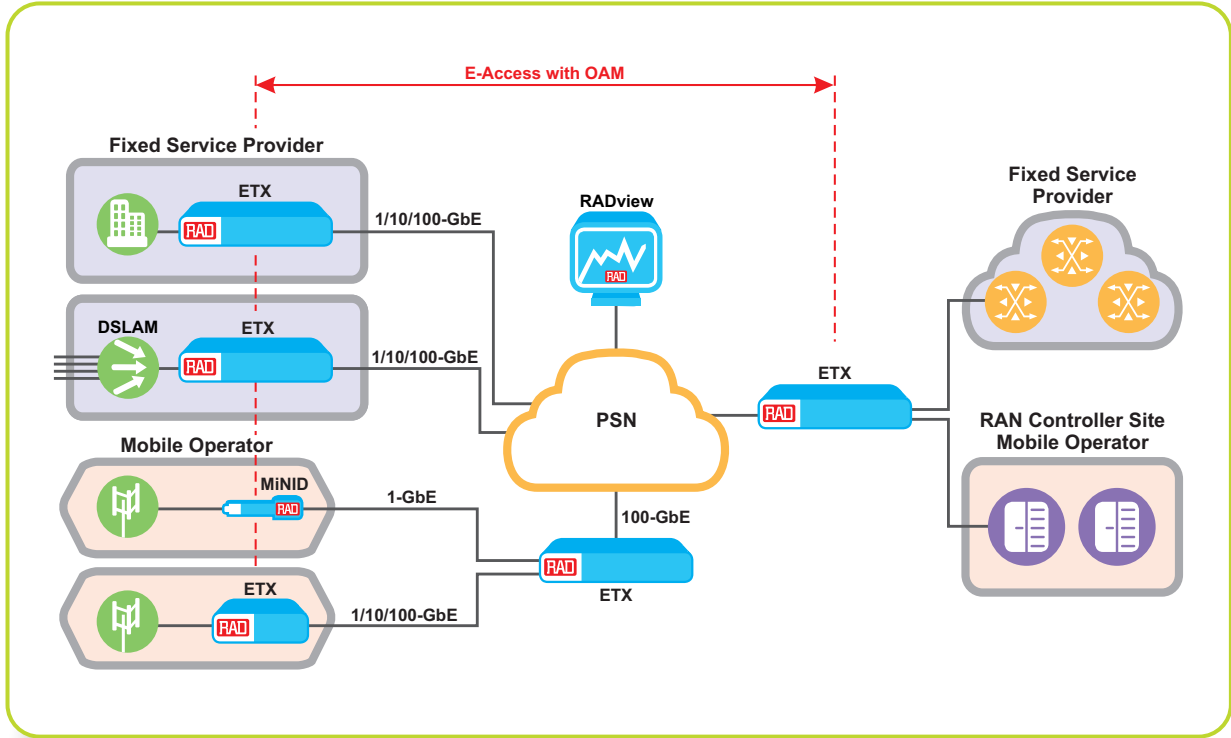

### Your Benefits:

- Provide wholesale Carrier Ethernet transport services to multiple service providers with complete visibility and controlled service hand-off between multiple networks
- Demarcation for business and mobile services, and broadband access node (e.g., PON) backhaul over the same transport network
- Provide SLA-based backhaul all the way to the end-customer site, cell site or POP, using a service assurance toolbox
- MEF-certified (CE 2.0 / MEF 3.0) E-Access support with single-CoS and/or multiple-CoS EVC/OVC for standards-based carrier-to-carrier connectivity
- Seamless connection between networks with 1-GbE, 10-GbE, 25-GbE and 100G E-NNI interfaces with optional redundancy
- Double fiber capacity while avoiding costly new fiber/transceiver deployments with BiDi QSFP 100G adaptors
- Support 5G convergence for wholesale services and L2 FWA



**ETX-2/ETX-2i**  
1/10/25/100G EADs, LTE/5G and Broadband Options



**MiNID**  
Miniature Programmable Network Interface Device



**BiDi QSFP Adaptor**  
100G Dual to Single Fiber Passive Adaptor



**RADview**  
Management and Domain Orchestration

